

Applicant: [Sabater Frau, Pedro](#)

Inventor: [Sabater Frau, Pedro](#)

Application nº: **Patent 201731103**

Int. Classification:

Title: **INTERNAL COMBUSTION ENGINE**

### Description:

The present invention refers to a internal combustion engine which comprises a block that includes at least one cylindrical hollow where a piston is housed and where said cylindrical hollow is closed by a head end with a fixed plate which has a first opening for air and fuel intake and a second opening for the expulsion of combustion gases; and where the opening and closing of said openings is carried out with a mobile plate with rotational mobility.

### Advantages of the invention:

*The objective of the invention is to improve and simplify the head of the block of an internal combustion engine, suppressing the valve system, tappets, rocker arms, camshaft and other related conventional elements.*

Classification: [Automotive](#); [Optimisation of combustion engines](#).

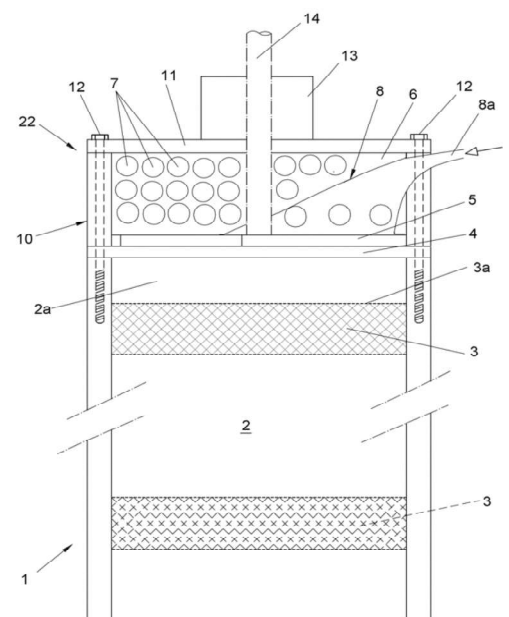

FIG. 1